

## Datasheet

### Mounting frame double

Part No: 100489, 100490

#### About the product

The high-quality mounting frame double made of anodized aluminum is perfect for mounting the Intercom, NFC Code Touch (Gen. 2) or Touch Pure on any facade.

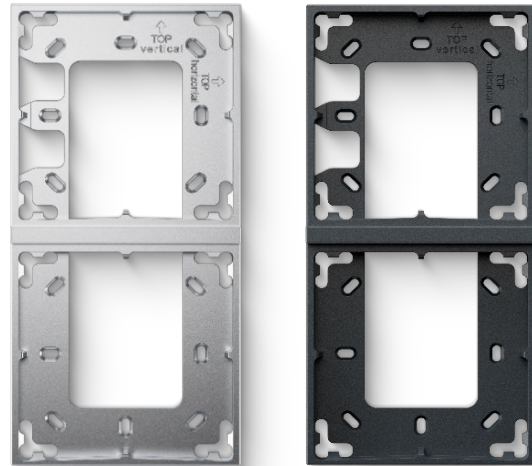

#### Product Characteristics

Material	Aluminium
Colours	Silver: RAL9003 - Part No. 100489 Anthracite: RAL7021 - Part No. 100490

#### Dimensions & Weight

Net weight	65g
Total weight	80g
Product dimensions	188x90x15.5mm / 7.4x3.55x0.61" (LxWxH)

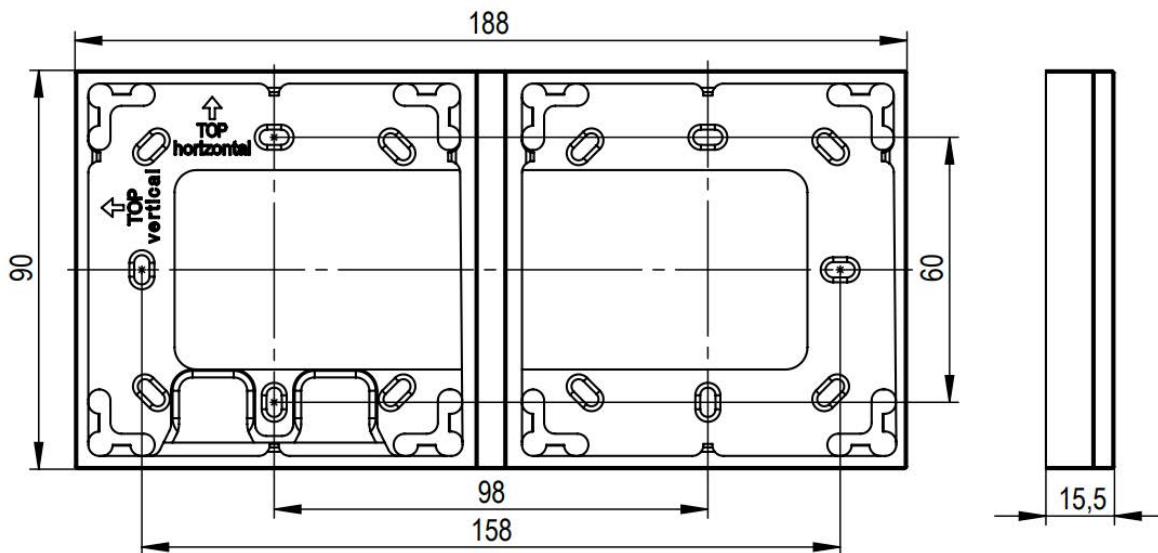

Pack size	204x107x39mm / 8.03x4.21x1.54" (LxWxH)
-----------	--

#### Published by

**Loxone Electronics GmbH**

Smart Home 1

4154 Kollerschlag

Austria

Tel: +43 7287 7070-0

loxone.com

## Datenblatt

### Montagerahmen 2fach

Art. Nr. 100489, 100490

#### Information zum Produkt

Der hochwertige 2fach Montagerahmen aus eloxiertem Aluminium eignet sich perfekt zur Befestigung der Intercom, des NFC Code Touch (Gen. 2) oder des Touch Pure auf jeder Fassade.

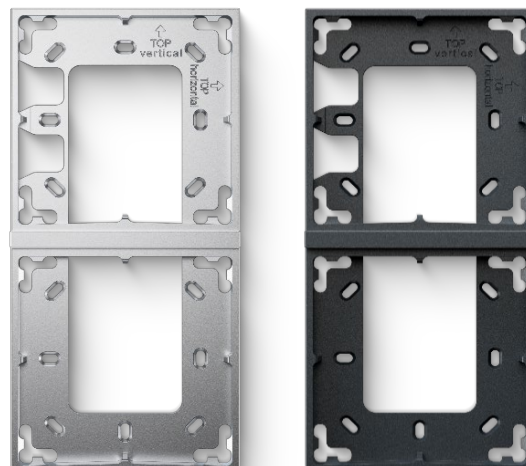

#### Produkteigenschaften

Material	Aluminium
Farbe	Silber: RAL9003 - Art. Nr. 100489 Anthrazit: RAL7021 - Art. Nr. 100490

#### Abmessungen & Gewicht

Nettogewicht	65g
Bruttogewicht	80g
Produktmaße	188x90x15,5mm / 7,4x3,55x0,61" (LxBxH)

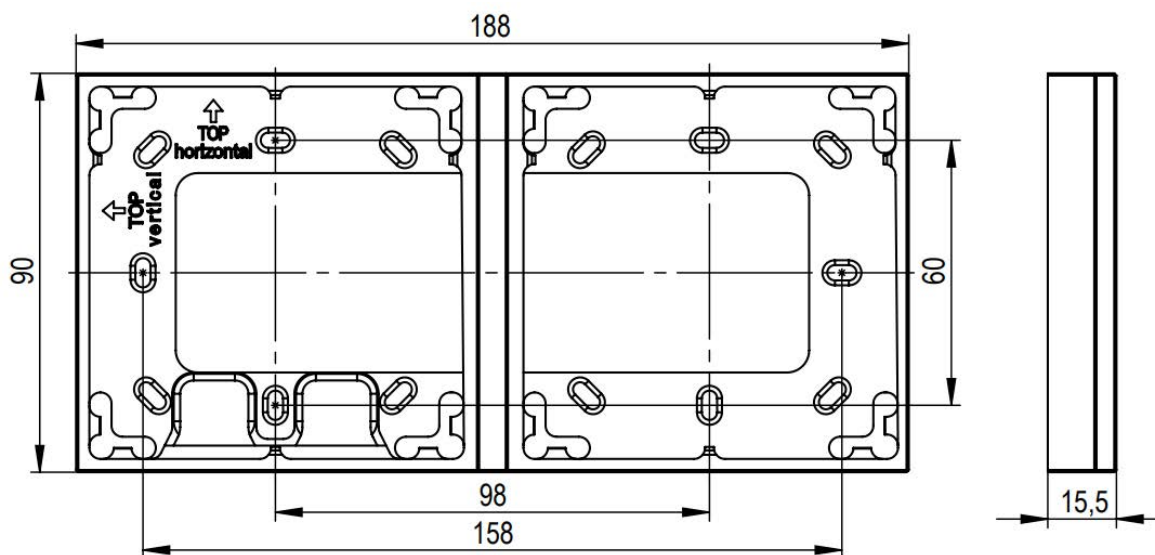

Packmaß	204x107x39mm / 8,03x4,21x1,54" (LxBxH)
---------	--

#### Veröffentlicht von

**Loxone Electronics GmbH**

Smart Home 1

4154 Kollerschlag

Austria

Tel: +43 7287 7070-0

loxone.com